

# ***PARTNER***

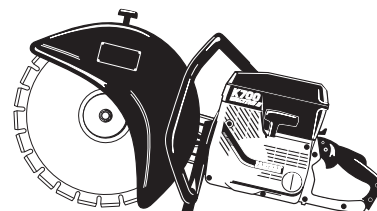

IPL, K700 ACTIVE II, 1999-03, 106 25 80-61

***K700 ACTIVE II***

***Reservdelar***

***Spare parts***

***Ersatzteile***

***Pieces de rechange***

***Piezas de repuesto***

***Ricambi***

***Peças  
sobresselente***

106 25 80-61

---

**PARTNER®**

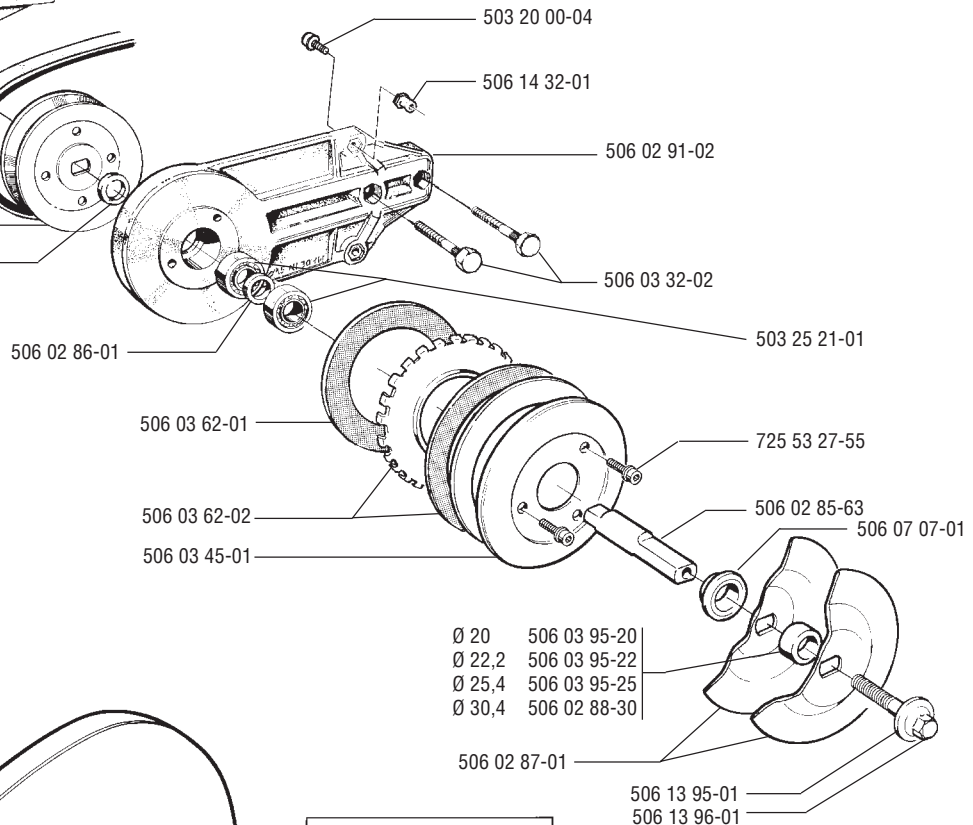
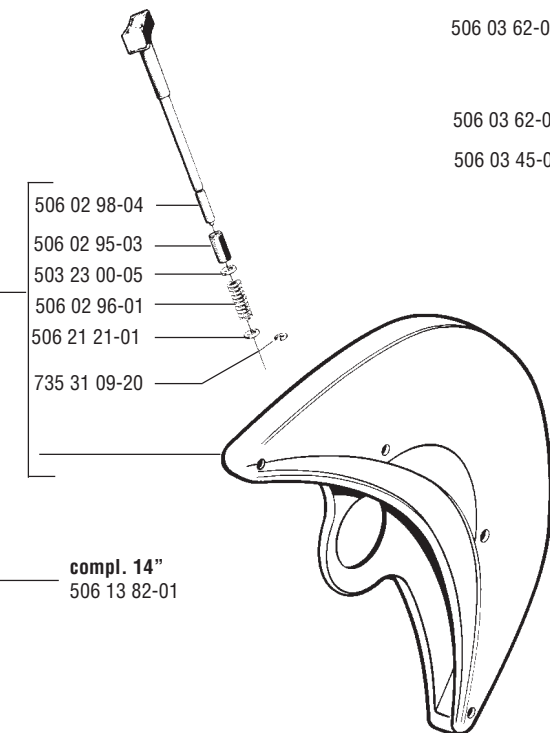
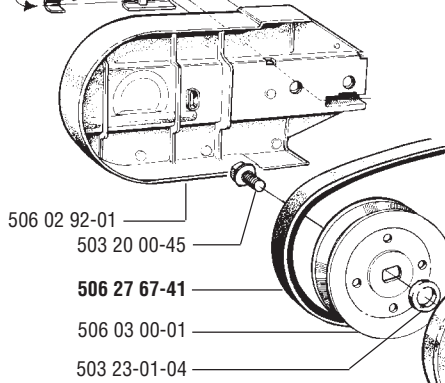
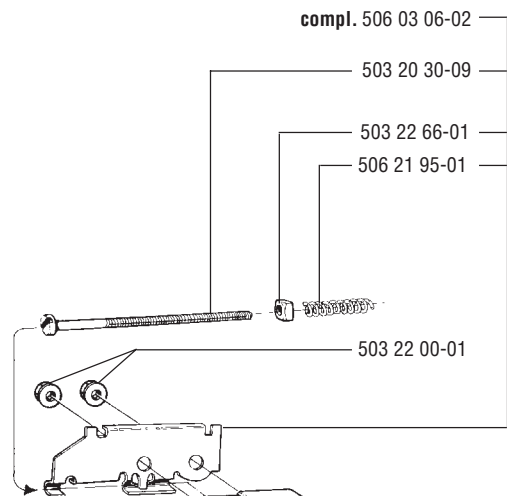
**A**

● Maskinen får ej användas innan skylt med rätt spindelvarvtal monterats.  
 ● The machine must not be used before the label is mounted stating correct spindle speed.  
 ● Dieses Gerät darf erst nach montage des Typschil- des mit Spindelrevolutions-Angabe benutzt werden.  
 ● La machine ne devra être mise en service qu' après installation préalable d' une plaque indiquant la valeur correcte pour la vitesse de rotation de la broche.

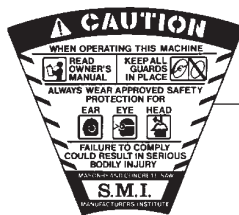
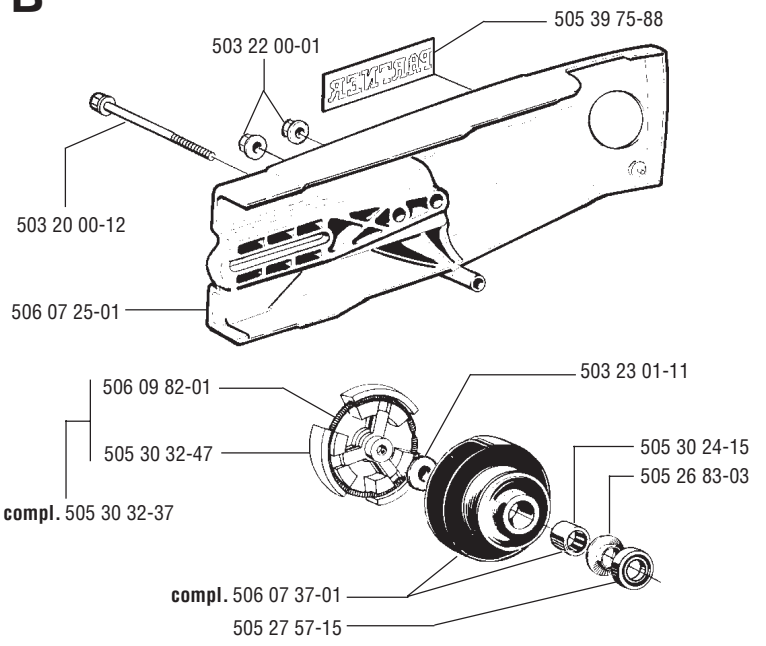
**B**

506 03 88-01

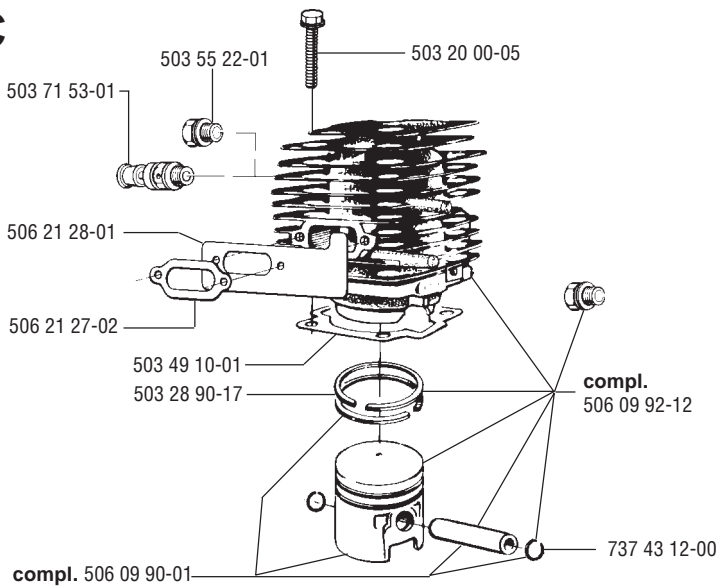
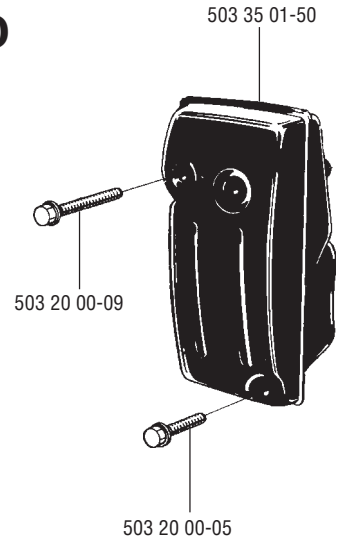
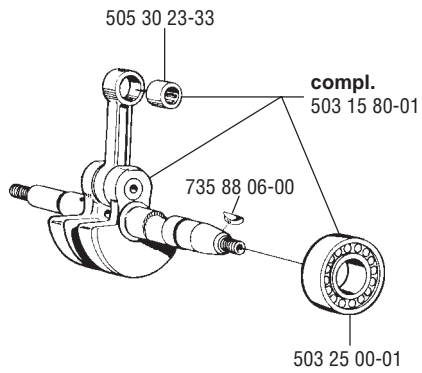
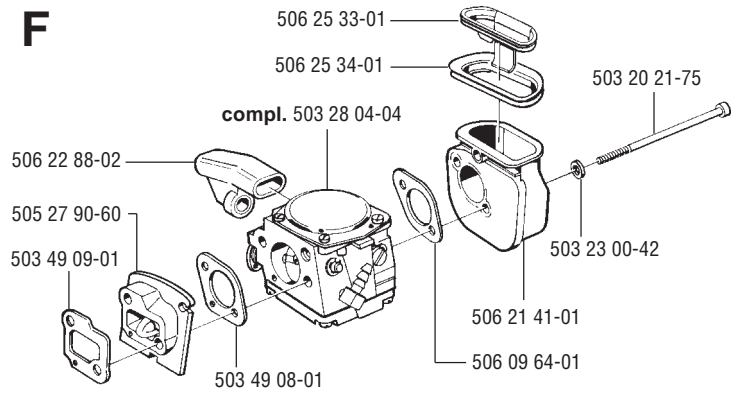
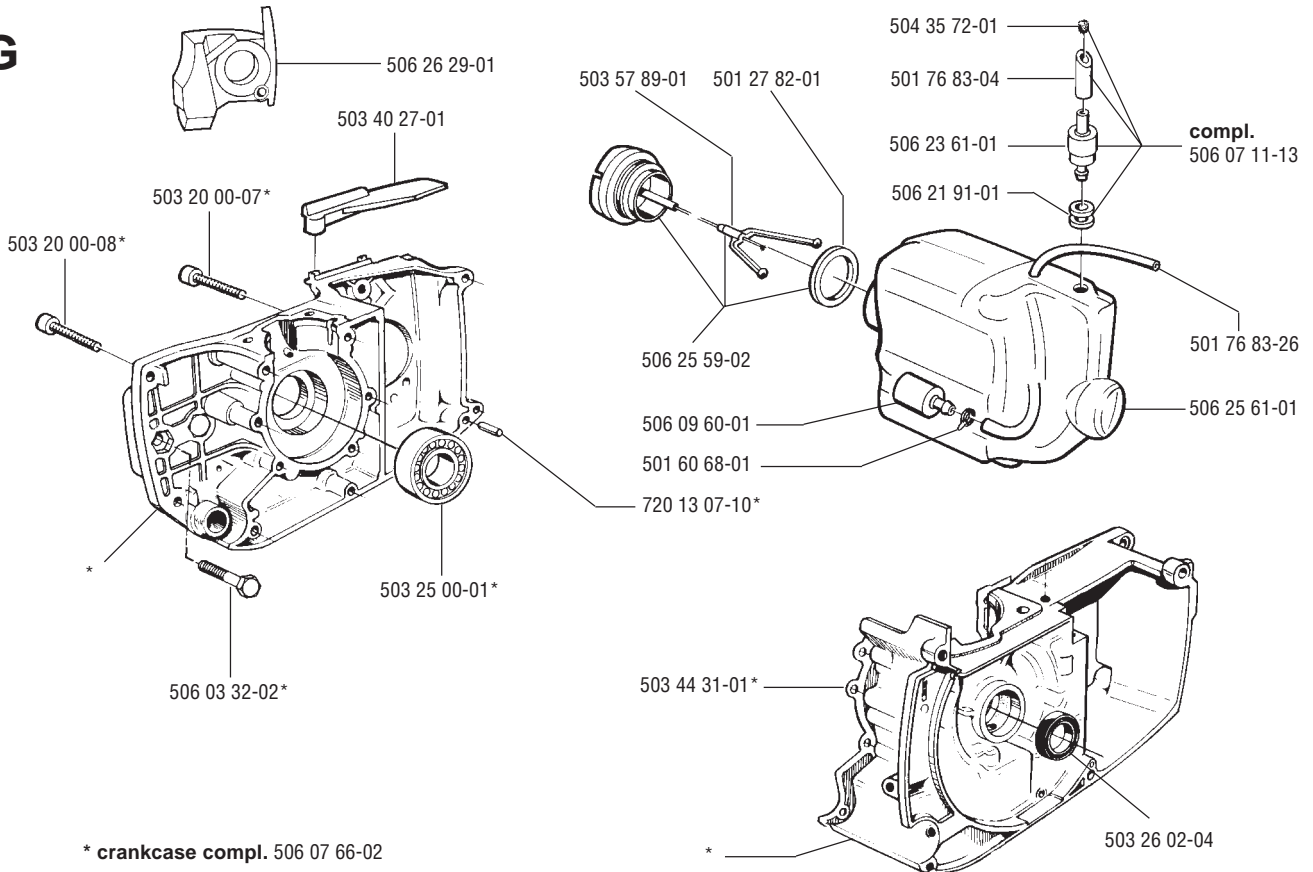
**C****D****E****F****G**

H

506 23 64-31 CE



503 20 34-42

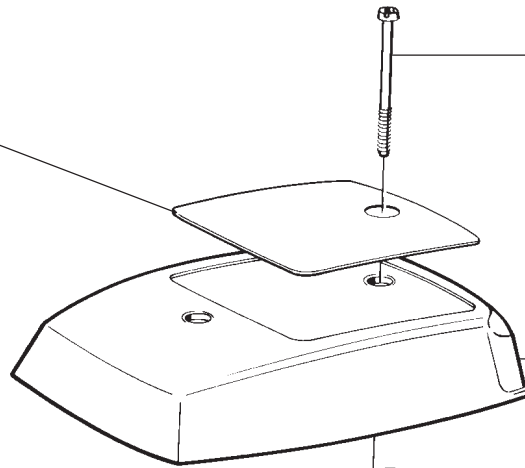

506 21 79-01

\*\*506 25 82-01

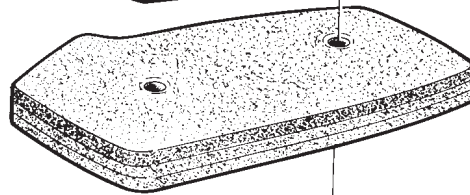

506 22 63-01

\*\*506 28 39-30

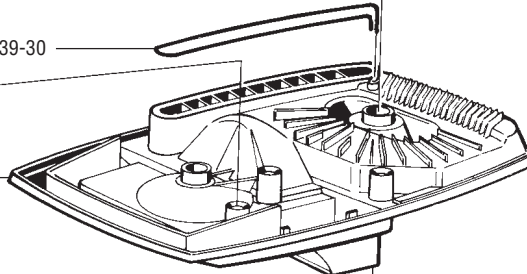

compl. 506 22 42-72

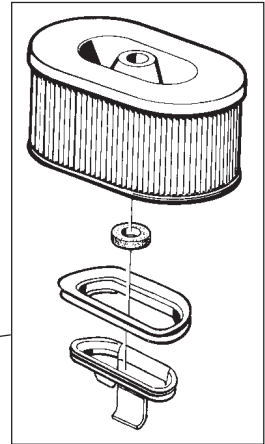

\*\*compl. 506 21 78-12

503 20 02-90



506 28 39-30\*



\*compl. 506 21 77-14

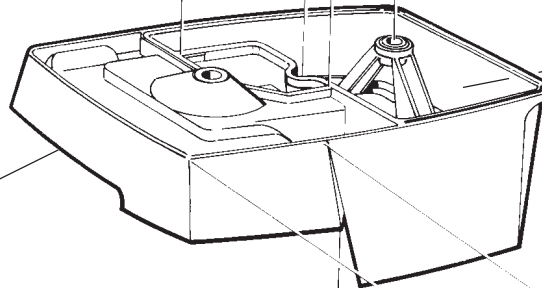

506 23 93-01\*

506 22 23-01



506 23 53-05

506 22 24-01

725 52 95-55

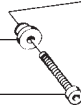

506 21 98-01

503 20 00-03

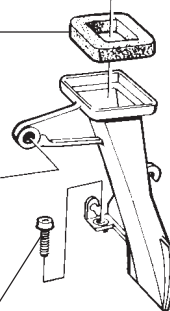

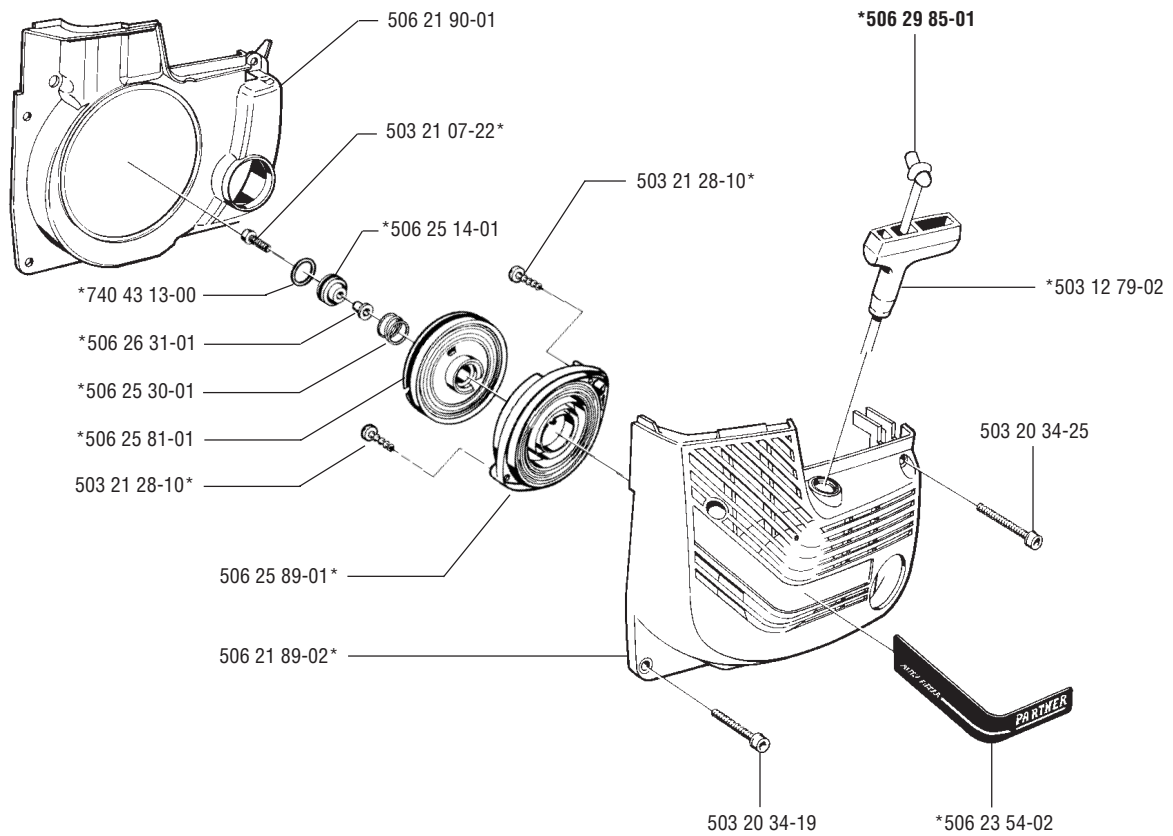
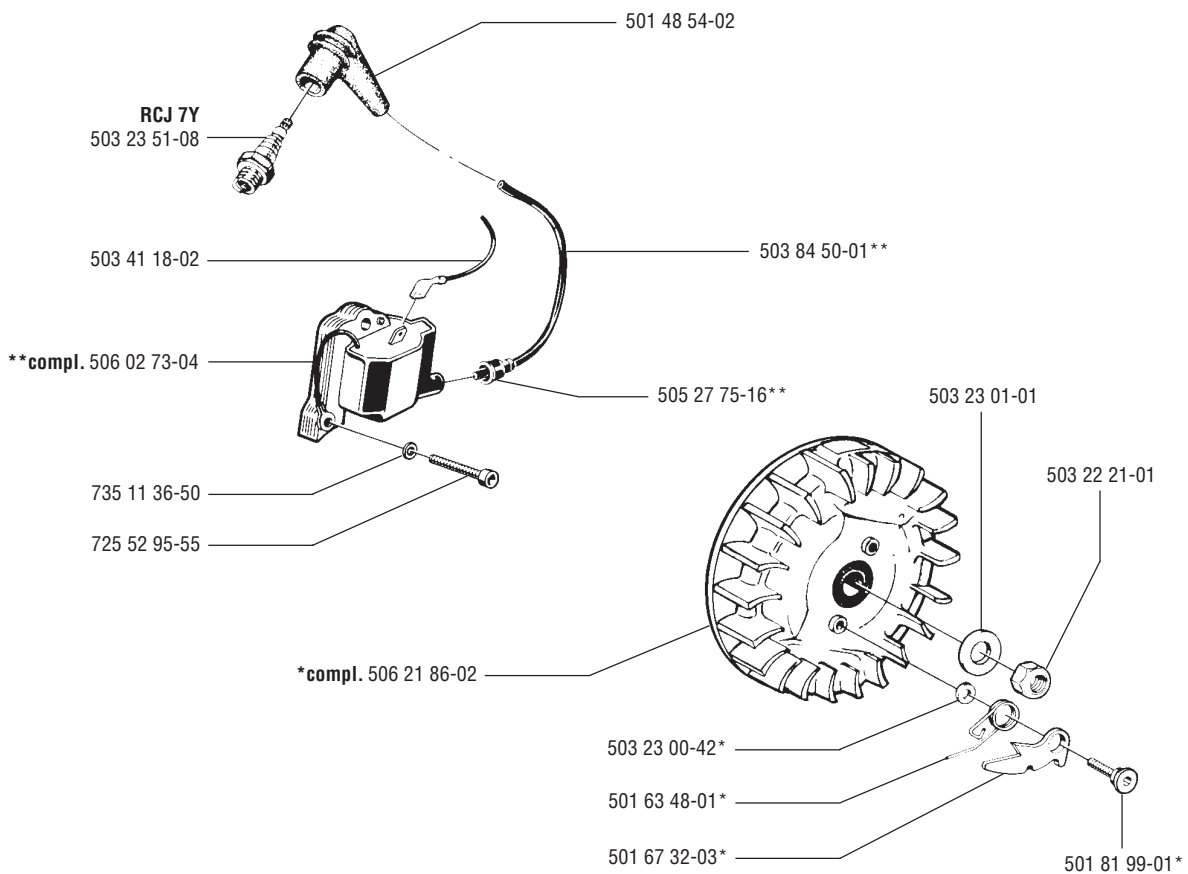
**J****K**

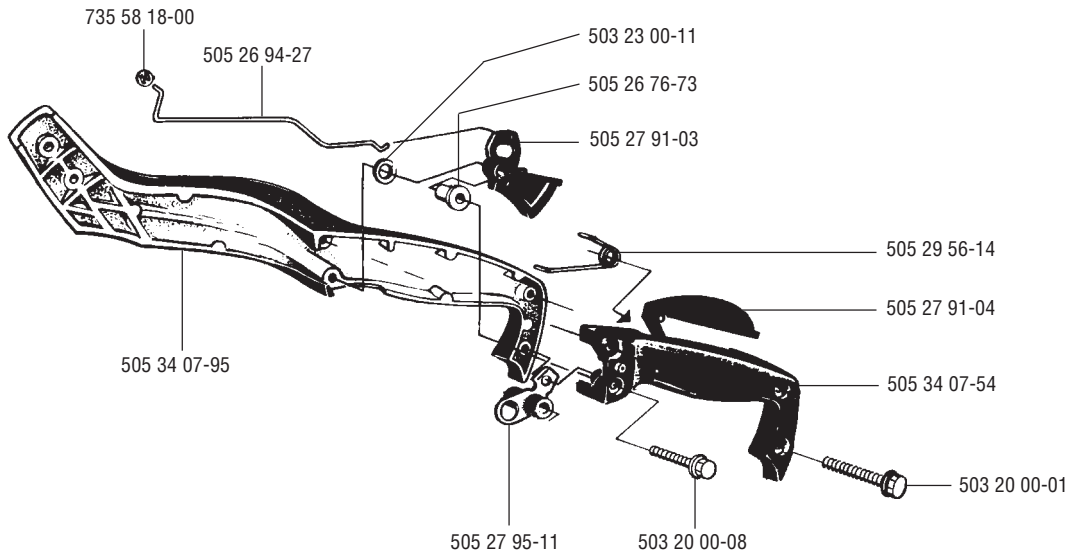
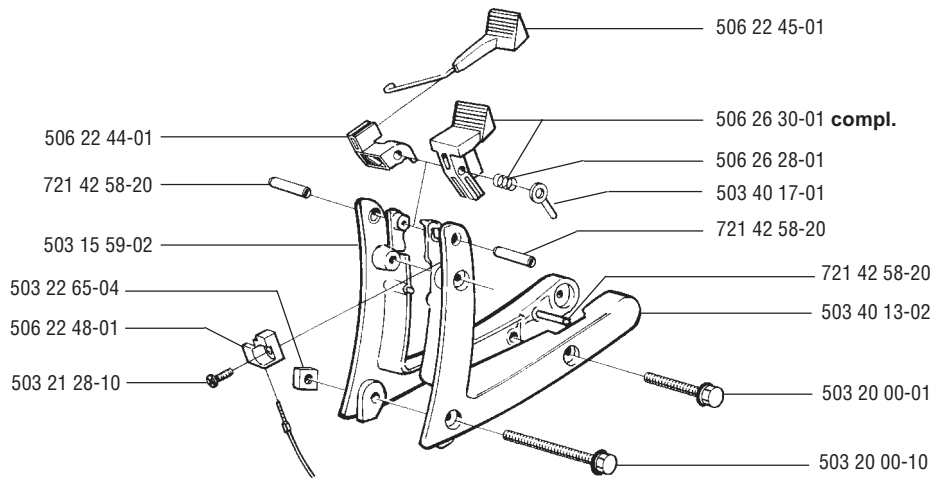
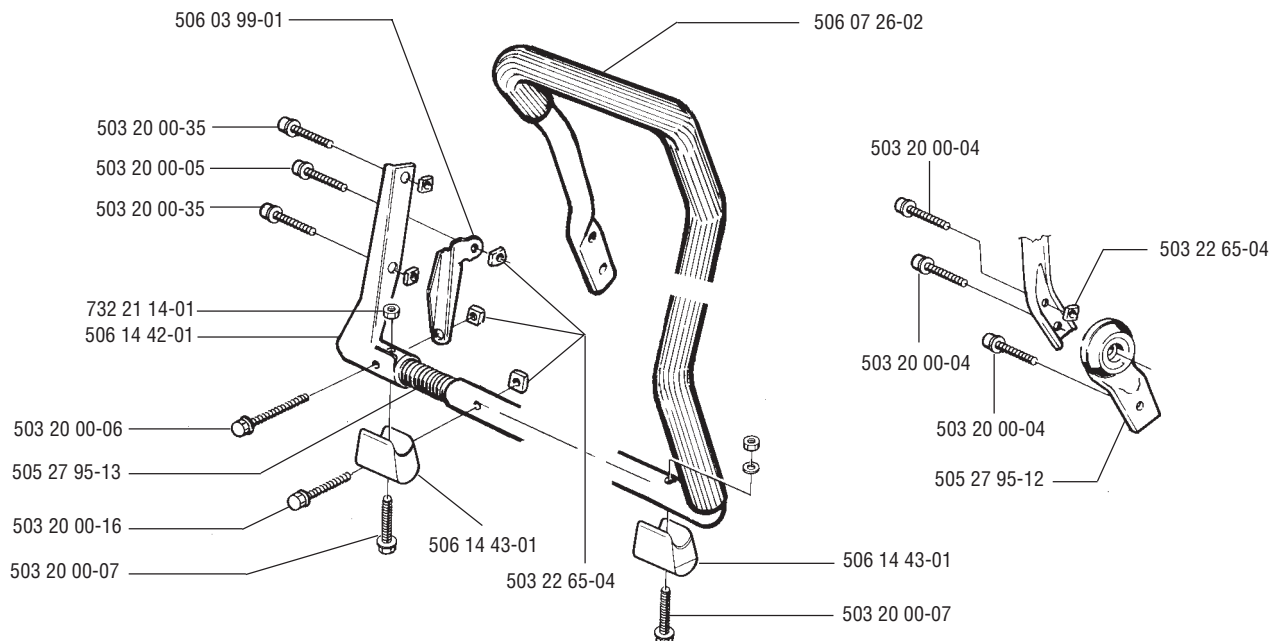
**L****M****N**

O

Compl. 503 28 04-04  
Tillotson HS 175G



506 27 63-01 (G)



506 25 88-01\*

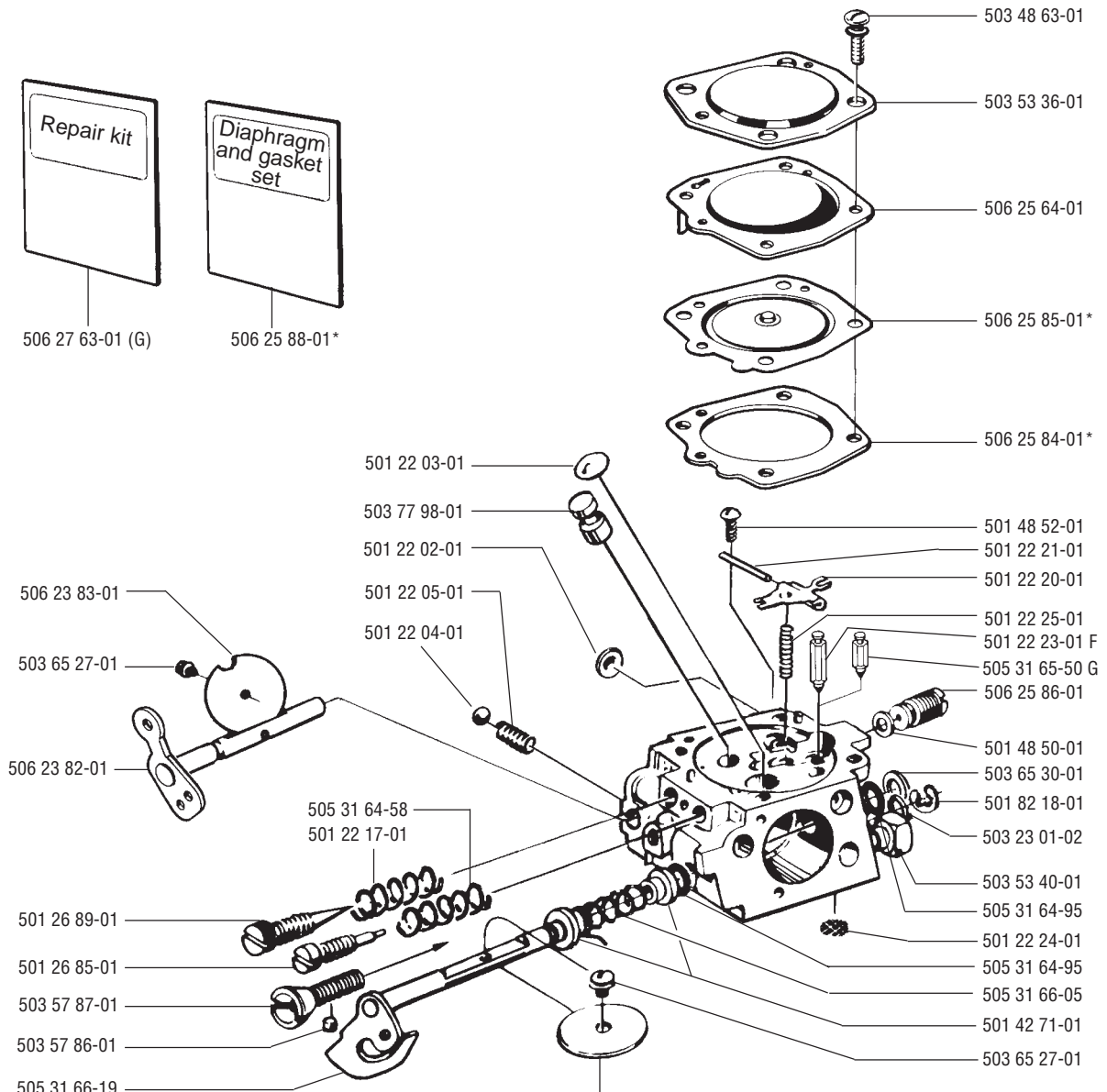

P



506 23 52-02

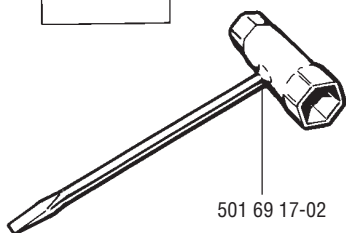

501 69 17-02

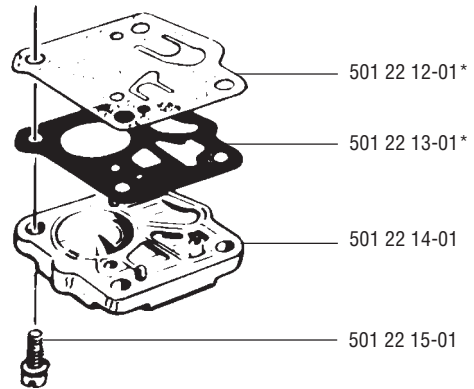

No.	Pos.	Denomination	No.	Pos.	Denomination	No.	Pos.	Denomination
501 22 02-01	O	Plug	503 44 31-01	G	Gasket	506 09 60-01	G	Filter
501 22 03-01	O	Plug	503 47 83-01	O	Shutter	506 09 64-01	F	Gasket
501 22 04-01	O	Ball	503 48 63-01	O	Cover screw	506 09 82-01	B	Spring
501 22 05-01	O	Spring	503 49 08-01	F	Gasket	506 09 90-01	C	Piston cpl 50 mm
501 22 12-01	O	Fuel pump diaphragm	503 49 09-01	F	Gasket	506 09 92-12	C	Cylinder cpl
501 22 13-01	O	Gasket, pump side	503 49 10-01	C	Gasket	506 13 82-01	A	Guard
501 22 14-01	O	Cap	503 53 36-01	O	Cover	506 13 95-01	A	Washer
501 22 15-01	O	Screw	503 53 40-01	O	Nipple	506 13 96-01	A	Screw
501 22 17-01	O	Spring	503 55 22-01	C	Plug	506 14 32-01	A	Catch
501 22 20-01	O	Lever	503 57 86-01	O	Ball	506 14 42-01	N	Support
501 22 21-01	O	Shaft	503 57 87-01	O	Screw	506 14 43-01	N	Support
501 22 23-01	O	Needle	503 57 89-01	G	Holder	506 21 21-01	A	Washer
501 22 24-01	O	Filter	503 65 27-01	O	Screw	506 21 23-01	H	Gasket
501 22 25-01	O	Spring	503 65 30-01	O	Washer	506 21 27-02	C	Gasket
501 26 85-01	O	Idle adj. screw	503 71 53-01	C	Valve decompr.	506 21 28-01	C	Deflector
501 26 89-01	O	Needle H	503 77 98-01	O	Valve	506 21 41-01	F	Inlet pipe
501 27 82-01	G	Washer	503 84 50-01	K	Cable	506 21 77-14	H	Cylinder cover
501 42 71-01	O	Bushing				506 21 78-12	H	Filter holder
501 48 50-01	O	Gasket	504 35 72-01	G	Fuel filter	506 21 79-01	H	Filter cover
501 48 52-01	O	Screw				506 21 86-02	K	Flywheel compl.
501 48 54-02	K	Spark plug conn. kit	505 26 76-73	L	Spacer	506 21 89-02	J	Starter housing
501 60 68-01	G	Clamp	505 26 83-03	B	Cover	506 21 90-01	J	Air conductor
501 63 48-01	K	Spring	505 26 94-27	L	Throttle rod	506 21 91-01	G	Grommet
501 67 32-03	K	Pawl	505 27 57-15	B	Seal ring	506 21 95-01	A	Spring
501 69 17-02	P	Comb. tool	505 27 75-16	K	Insulating cap	506 21 98-01	H	Air jet
501 76 83-04	G	Hose	505 27 90-60	F	Insul. flange	506 22 23-01	H	Sealing
501 76 83-26	G	Hose, 245 mm	505 27 91-03	L	Throttle control	506 22 24-01	H	Sealing
501 81 99-01	K	Screw M5x14	505 27 91-04	L	Throttle catch	506 22 42-72	H	Air filter
501 82 18-01	O	Retaining ring	505 27 95-11	L	Absorber	506 22 44-01	M	Guide
			505 27 95-12	N	Absorber	506 22 45-01	M	Choke control
503 12 79-02	J	Starter handle	505 27 95-13	N	Absorber	506 22 48-01	M	Holder
503 15 59-02	M	Bracket right	505 29 56-14	L	Spring	506 22 63-01	H	Filter
503 15 80-01	E	Crankshaft	505 30 23-33	E	Needle bearing	506 22 88-02	F	Guide
503 20 00-01	L,M	Screw M6SF 5x20	505 30 24-15	B	Needle bearing	506 23 52-02	P	Gasket set
503 20 00-03	H	Screw M6SF 5x12	505 30 32-37	B	Clutch	506 23 53-05	H	Decal
503 20 00-04	A,N	Screw M6SF 5x16	505 30 32-47	B	Centrif. weight	506 23 54-02	J	Decal
503 20 00-05	C,D,N	Screw M6SF 5x25	505 31 64-58	O	Pressure spring	506 23 61-01	G	Tank vent.
503 20 00-06	N	Screw M6SF 5x35	505 31 64-95	O	Sealing ring	506 23 64-31	H	Decal
503 20 00-07	G,N	Screw M6SF 5x40	505 31 65-50	O	Needle	506 23 82-01	O	Choke shaft
503 20 00-08	G,L,N	Screw M6SF 5x30	505 31 66-05	O	Spring	506 23 83-01	O	Choke flap
503 20 00-09	D	Screw M6SF 5x45	505 31 66-19	O	Throttle shaft	506 23 93-01	H	Decal
503 20 00-10	M	Screw M6SF 5x55	505 34 07-54	L	Handle, left half	506 25 14-01	J	Washer
503 20 00-12	B	Screw M6SF 5x70	505 34 07-95	L	Handle, right	506 25 30-01	J	Spring
503 20 00-16	N	Screw M6SF 5x28	505 35 01-50	D	Silencer	506 25 33-01	O	Insert
503 20 00-35	N	Screw	505 39 75-13	A	Information label	506 25 34-01	O	Sealing
503 20 00-45	A	Screw	505 39 75-88	B	Decal	506 25 59-02	G	Tank cap
503 20 02-90	H	Screw				506 25 61-01	G	Tank unit
503 20 21-75	F	Screw	506 02 73-04	K	Ignition module	506 25 64-01	O	Insert
503 20 30-09	A	Screw	506 02 84-01	A	Washer	506 25 81-01	J	Starter pulley
503 20 34-19	J	Screw	506 02 85-63	A	Shaft	506 25 82-01	H	Guard
503 20 34-25	J	Screw	506 02 86-01	A	Spacer	506 25 84-01	O	Gasket
503 20 34-42	H	Screw	506 02 87-01	A	Washer	506 25 85-01	O	Diaphragm
503 21 07-22	J	Screw	506 02 88-30	A	Bushing	506 25 86-01	O	Governor
503 21 28-10	J,M	Screw	506 02 91-02	A	Bearing housing	506 25 88-01	O	Diaphragm and gasket set
503 22 00-01	A,B	Nut M6MF M5	506 02 92-01	A	Guard	506 25 89-01	J	Return spring
503 22 21-01	K	Lock nut M8x1	506 02 95-03	A	Hose	506 25 95-01	J	Starter device
503 22 65-04	M,N	Nut	506 02 96-01	A	Spring	506 26 28-01	M	Spring
503 22 66-01	A	Nut	506 02 98-04	A	Control knob	506 26 29-01	G	Protector
503 23 00-05	A	Washer 6.5x11	506 03 00-01	A	Pulley	506 26 30-01	M	Knob
503 23 00-11	L	Washer 5.3x12	506 03 06-02	A	Adjuster	506 26 31-01	J	Sleeve
503 23 00-35	N	Washer 5.3x15	506 03 32-02	A,G	Screw	506 27 63-01	O	Repair kit
503 23 00-42	F,K	Washer	506 03 45-01	A	Washer	<b>506 27 67-41</b>	A	Belt
503 23 01-01	K	Washer 8.4x16	506 03 62-01	A	Spacer	506 28 39-30	H	Sealing
503 23 01-02	O	Washer 5.25x9	506 03 62-02	A	Spacer	<b>506 29 85-01</b>	J	Starter rope
503 23 01-04	A	Washer 15x21	506 03 62-04	A	Spacer			
503 23 01-11	B	Washer	506 03 88-01	A	Warning label	720 13 07-10	G	Pin
503 23 51-08	K	Spark plug RCJ7Y	506 03 95-20	A	Bushing	721 42 58-20	M	Spring pin 4x24
503 25 00-01	E,G	Ball bearing MFG SKF	506 03 95-22	A	Bushing	725 52 95-55	H,K	Screw MC6S 4x20
503 25 21-01	A	Ball bear. 6202 DDU/C3	506 03 95-25	A	Bushing	725 53 27-55	A	Screw MC6S 5x12
503 26 02-04	G	Sealing ring	506 03 99-01	N	Support	732 21 14-01	N	Locknut M5
503 28 04-04	F,O	Carburettor	506 07 07-01	A	Flange, support	735 31 09-20	A	E-ring 5
503 28 90-17	C	Piston ring	506 07 11-13	G	Hose	735 58 18-00	L	Lock washer 2.4
503 40 13-02	M	Bracket left	506 07 25-01	B	Cutting arm	735 88 06-00	E	Woodruff key
503 40 17-01	M	Contact spring	506 07 26-02	N	Handle	737 43 12-00	C	Retaining ring
503 40 27-01	G	Spacer	506 07 37-01	B	Drive wheel	740 43 13-00	J	O-ring
503 41 18-02	K	Cable	506 07 66-02	G	Crankcase cpl			

